



PCSAW 530 X/AX band saw machine

Fully automatic with pulse cutting technology



PCSAW 530 X/AX

The innovative AMADA pulse cutting technology sets new standards

Conceived for heavy-duty use in the steel trade and in production, the AMADA PCSAW series features a number of technical highlights.



PULSE CUTTING TECHNOLOGY

The pulse cutting technology developed by AMADA has revolutionised band sawing like no other process.

Predefined loading and unloading of the band saw blade in the feed direction generates a wave-like up-and-down motion of the saw band that has a positive effect on the sawing process.

The main advantages are:

- low cutting resistance
- more effective tooth contact
- low thermal load due to shorter chipping and improved cooling action of the cooling lubricant
- larger band saw blade service life

Basically, it is possible to use either carbide tipped or bimetal bandsaw blades in the metal distribution.

The corresponding sawing parameters for more than 200 materials are stored in the CNC controller for both band types.

If special materials such as Hastelloy or Inconel are sawed, the AX version is recommended where saw feeding takes place via a precision, servo-electric ball screw drive. In contrast, the PCSAW 530 X model operates with the proven servo-hydraulic AMADA saw feed.

OTHER FEATURES

Because of the larger quantities of saw chips resulting from the enormous cutting performance, AMADA paid special attention to perfect chip removal with the PCSAW 530.

On the one side, the new „3D double wire brush unit“. Two automatically adjusting wire brushes ensure very effective brush-off of the saw chips.

The subsequent, smooth removal of the chips is taken over by an extensively dimensioned scraper conveyor.

The new AMADA solution for manual sawing of small remnants which allows shorter material lengths to be inserted from the front of the machine is particularly interesting for many users.

After entering the desired cutting length into the CNC controller, a robust stopping plate fixed to the feeding vice is positioned to the corresponding cutting length, against which the material to be sawed can be pushed. The otherwise essential and time-consuming measuring of the material is no longer necessary.

A large number of innovative ideas were realised during conception of the new PCSAW 530 model for maintenance and process monitoring

- Cooling lubricant level monitor
- Tool-free chip filter removal
- Cutting accuracy monitor

OVERVIEW OF THE ADVANTAGES

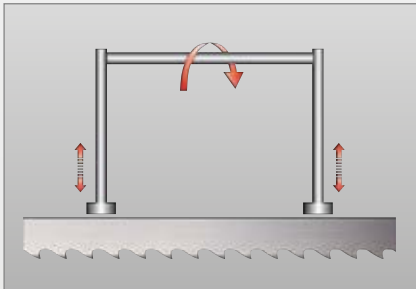

Pulse Cutting technology

The pulsation moves the saw up and down rapidly, generating a wave-like motion that has a positive effect on the cutting behaviour of the sawteeth, therefore reduces the cutting resistance and guides to increased blade lifetime.



User-friendly CNC machine controller

- Interactive menu control
- Integrated material database for bimetal and carbide tipped band saw blades



Servo-electric ball screw drive

- Exact feed control
- Constant feeding speed



3-D double wire brush

The two automatically adjusting wire brushes of the new „3-D double-brush unit“ guarantee thorough brushing of the sawed chips.

- Automatic positioning of the brushes
- Wear monitoring
- Wear indication on the screen

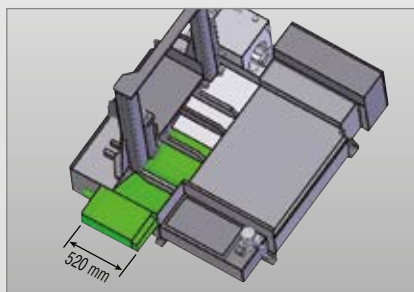

Wide scraper conveyor

- Conveyor width = 520 mm
- Extensively dimensioned
- Situated completely under the saw band line
- Smooth chip removal



Stop plate for remaining pieces

- Easy manual sawing up of remnants
- minimum length 35 mm

TECHNICAL DATA

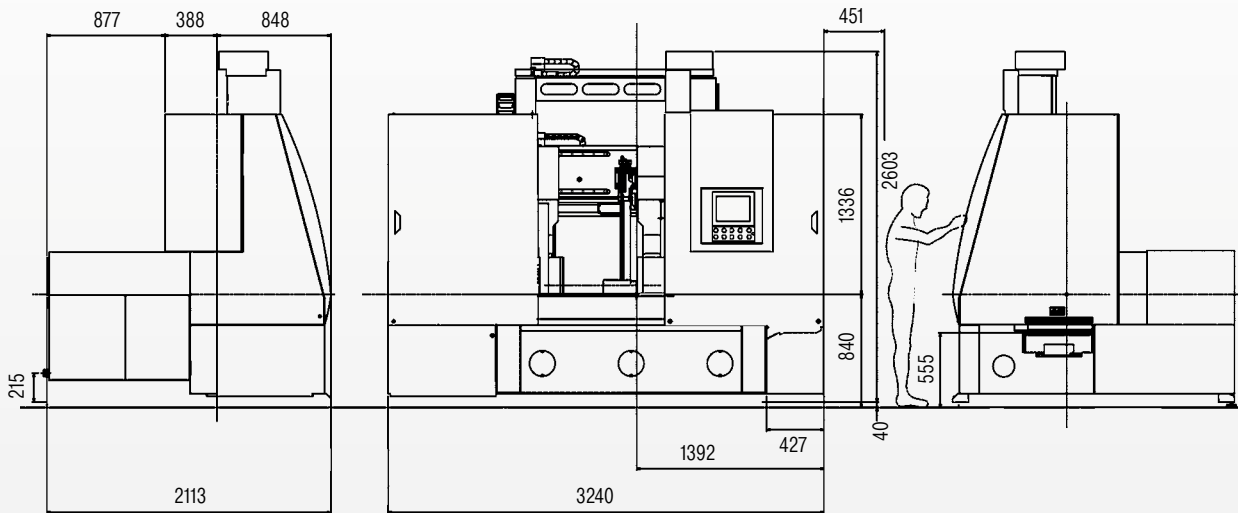

PCSAW 530 X / 530 AX technical data		
Sawing capacity	Round material Square material	○ 30 mm ~ ○ 530 mm □ 30 mm ~ □ 530 mm
Motor power	Saw Blade Motor Hydraulic Pump Motor	15 kW x 4P 2.2 kW x 4P
Bandsaw blade dimension	(H x W x L)	67 x 1.6 x 7000 mm
Band speed		15-120 m/min continuously variable
Vice	Hydr. cylinder Positioning	shared vice zero stop
Chip brush		3-D double-brush system with automatic adjustment
Chip conveyor		Large surface scraper conveyor
Material feed	Type Feed length Cut-off length	hydraulic feeding vice 500 mm per stroke 10 mm - 9999.9 mm
CNC controller		automatic parameter setting
Table height above floor		840 mm
Maximum work load		4600 kg
Machine dimensions	(W x D x H)	3240 x 2113 x 2603 mm
Machine weight		5500 kg
Special accessories		Bundle clamping unit, pressure reducing unit, roller conveyors, external chip conveyor

Subject to technical modifications / Illustrations partially with special accessories



AMADA MACHINE TOOLS EUROPE

AMADA MACHINE TOOLS EUROPE GmbH

Amada Allee 3, 42781 Haan, Germany

Tel.: +49 (0) 2104 177 70, Mail: info@amadamachinetools.de, www.amadamachinetools.de



740000116